

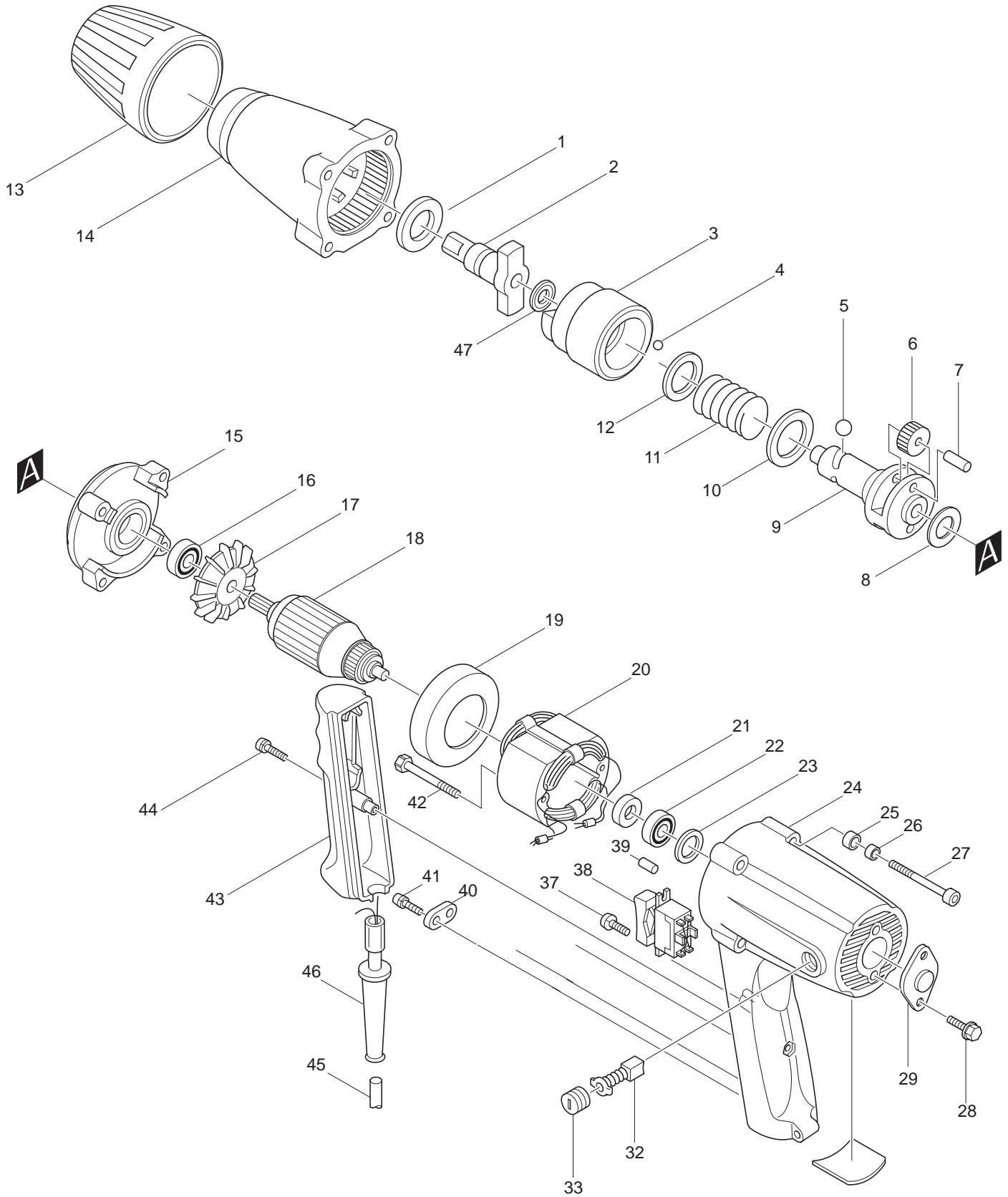

12 - 2009
6905B
1/2" IMPACT WRENCH



Item No	Type	Ref	Part No	Description	Qty	Unit
1			253937-2	FLAT WASHER 18	1	PC.
2			132383-1	ANVIL ASS'Y (OLD# 325546-8)	1	PC.
		INC.		Item No.902, 903		
3			322246-1	* HAMMER	1	PC.
4			216008-6	STEEL BALL 4	20	PC.
5			216007-8	STEEL BALL 6.4	2	PC.
6			221849-7	SPUR GEAR 33	2	PC.
7			256033-5	PIN 6	2	PC.
8			253794-8	FLAT WASHER 18	1	PC.
9			321118-7	SPINDLE	1	PC.
10			253751-6	FLAT WASHER 24	1	PC.
11			231261-3	COMPRESSION SPRING 24	1	PC.
12			253793-0	FLAT WASHER 22	1	PC.
13			421157-8	BUMPER	1	PC.
14			156544-9	HAMMER CASE	1	PC.
		INC.	213257-6	OIL SEAL 18	1	PC.
		INC.	221850-2	INTERNAL GEAR 73	1	PC.
		INC.	321119-5	SLEEVE 18	1	PC.
15			152145-1	BEARING HOUSING COMPLETE	1	PC.
16			211031-6	BALL BEARING 608LLB	1	PC.
17			241622-9	FAN 62	1	PC.
18			515131-7	ARMATURE ASS'Y 115V (OLD# 615131-8)	1	PC.
		INC.		Item No. 16,17,21,22		
19			411601-3	BAFFLE PLATE	1	PC.
20			625116-6	FIELD 115V	1	PC.
21			681614-0	INSULATION WASHER	1	PC.
22			210025-8	BALL BEARING 627LLB	1	PC.
23			262010-7	URETHANE RING 18	1	PC.
24			159161-4	MOTOR HOUSING	1	PC.
		INC.	643557-4	BRUSH HOLDER 5-8	2	PC.
		INC.		Item No. 39		
25			253929-1	CUP WASHER 5	4	PC.
26			262001-8	URETHANE RING 5	4	PC.
27			922903-7	HEX. SOCKET HEAD BOLT M5X50	4	PC.
28			921226-0	HEX. BOLT M5X18	2	PC.
29			285015-0	BEARING COVER 34	1	PC.
32	1		191947-0	CARBON BRUSH CB-76 2PC/SET (W/O ORIGIN) - N/L/A	1	SET
	2		194972-0	CARBON BRUSH SET CB-76 2PC/SET (W/ORIGIN)	1	SET
33			643550-8	BRUSH HOLDER CAP 5-8	2	PC.
37			911106-8	PAN HEAD SCREW M4X8	1	PC.
38			651564-3	SWITCH SL220SD-4 (OLD# 651554-6)	1	PC.
39			263002-9	RUBBER PIN 4	1	PC.
40			687002-9	STRAIN RELIEF	1	PC.
41			911133-5	PAN HEAD SCREW M4X18 (OLD# 911131-9)	2	PC.
42			265349-7	+ HEX. BOLT M4X50	2	PC.
43			411600-5	HANDLE COVER	1	PC.
44			911168-6	PAN HEAD SCREW M4X40	1	PC.
45			664064-4	CORD W/PLUG 2P-18-2.5M, SJ	1	PC.
46			682502-4	CORD GUARD 8-85	1	PC.
47			261074-8	* NYLON WASHER 22 (Added)	1	PC.
100			654037-5	INSLTED TERMINAL FK1.25-M3 (F/SWITCH)	4	PC.
102			652008-6	P.H. SCREW M3.5 X 7 (F/SWITCH)	4	PC.
103			654509-0	CLOSED END TERMINAL 2-SD (F/CORD, FIELD)	2	PC.

Item No	Type	Ref	Part No	Description	Qty	Unit
104			654018-9	GARTER SPRING	2	PC.
105			654501-6	TERMINAL P-1.25	2	PC.
106			931102-0	HEX NUT M4 (F/MOTOR HOUSING)	1	PC.
200			256187-8	PIN	1	PC.
201			953106-2	RIVET 0-5 (F/NAME PLATE) (Old)	4	PC.
202			913206-0	SET SCREW M5 X 8 (F/MOTOR HOUSING)(Old)	2	PC.
902			322045-1	CLIP	1	PC.
903	1		323675-1	* PIN 4 (ROUND HEAD)	1	PC.
	2		268098-5	* PIN 4 (FLAT HEAD)	1	PC.
907			819003-1	MAKITA LABEL	1	PC.

ACCESSORIES

- See catalogue or visit www.makita.ca for optional accessory -

A01			824698-7	PLASTIC CARRYING CASE	1	PC.
	INC.		182935-8	SLIDE LATCH (R.L) SET	1	SET
A02			134877-2	UNIVERSAL JOINT 1/2" - LARGE (With Item No.200)	1	PC.
A03			134874-8	EXTENSION BAR 12.7 ASSY (With Item No.200)	1	PC.
A04			783202-0	HEX WRENCH 4	1	PC.
A05			194485-1	FLAT PIN 4 SET	1	PC.
	INC.		268098-5	PIN 4 (FLAT HEAD)	1	PC.
	INC.		322045-1	CLIP	1	PC.
	INC.		345842-8	HOOK (Not available as an individual part)	1	PC.
A06			195871-9	DRILL BIT REMOVER SET	1	PC.

SERVICE CHANGES

1. Changes on Pin 4

Item No.	Description	Type 1	Type 2
903	PIN 4	323675-1 (Round head)	268098-5 (Flat head)

*For easy conversion, use Flat Pin 4 Set (194485-1) (Item No. A05).

TYPE1:

Removing way of the socket:
Simply pull the socket off.

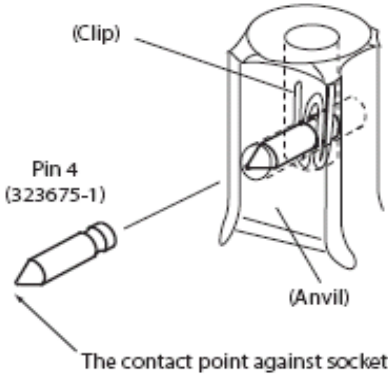

TYPE2:

Removing way of the socket:
Depress the detent pin through the hole in the socket and pull the socket off the anvil.

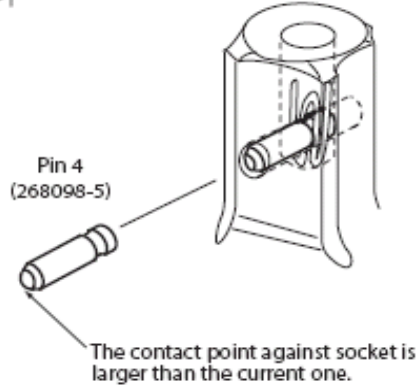

2. Changes on Hammer

Item No.	Description	Type 1	Type 2
3	HAMMER	321117-9 (N/L/A)	322246-1
47	NYLON WASHER 22	-----	261074-8

Above parts are completely interchangeable as a set.

Type 1

Type 2

